

10-13-1989

Data Acquisition and Presentation in Scanning Nuclear Microprobe Analysis

K. G. Malmqvist

Lund Institute of Science and Technology

N. E. G. Lövestam

Lund Institute of Science and Technology

J. Pallon

Lund Institute of Science and Technology

U. A. S. Tapper

Lund Institute of Science and Technology

Follow this and additional works at: <https://digitalcommons.usu.edu/microscopy>

 Part of the [Biology Commons](#)

Recommended Citation

Malmqvist, K. G.; Lövestam, N. E. G.; Pallon, J.; and Tapper, U. A. S. (1989) "Data Acquisition and Presentation in Scanning Nuclear Microprobe Analysis," *Scanning Microscopy*. Vol. 3 : No. 3 , Article 9. Available at: <https://digitalcommons.usu.edu/microscopy/vol3/iss3/9>

This Article is brought to you for free and open access by the Western Dairy Center at DigitalCommons@USU. It has been accepted for inclusion in Scanning Microscopy by an authorized administrator of DigitalCommons@USU. For more information, please contact digitalcommons@usu.edu.



DATA ACQUISITION AND PRESENTATION IN SCANNING NUCLEAR MICROPROBE ANALYSIS

K.G. Malmqvist*, N.E.G. Lövestam, J. Pallon and U.A.S. Tapper

Department of Nuclear Physics, Lund Institute of Science and Technology,
Sölvegatan 14, S-223 62 LUND, Sweden

Phone No.: (046) 107684

(Received for publication April 27, 1989, and in revised form October 13, 1989)

Abstract

The data acquisition is a very important part of the scanning nuclear microprobe instrument. To make full use of the potential of the technique an adequate system for acquiring, storing, processing and presenting the data is a prerequisite. Various principles applied are presented including the list mode approach, which facilitates flexible off-line data processing. As in the case of the electron probe the beam-induced effects in the sample may be substantial and the list mode acquisition can then also be used to monitor and correct for any such effects. A comprehensive system for scanning nuclear microprobe control and data acquisition, based on a combination of a VMEbus computer system and a μ Vax-II computer, is described in some detail.

Introduction

Microanalytical techniques based on ion beams from accelerators, nuclear microprobes, are of growing importance in various fields of application. Methods such as Particle Induced X-ray Emission (PIXE) and Rutherford Backscattering (RBS) yield data on elemental concentrations which could be highly valuable, e.g., in biology, mineralogy and materials science. Using the Scanning Nuclear microprobe (SNM) with several detectors for simultaneous analysis with these techniques, complete data acquisition often requires several parameters to be recorded. In addition, the results from compilation of these raw data should preferably be presented in a user-friendly way utilizing, for example, new methods from the rapidly developing field of image processing. Due to the complexity of the detection system the scanning nuclear microprobe, although in many ways similar, places higher demands on data acquisition and computing facilities than is normally the case for traditional microprobe techniques, e.g., the electron microprobe.

This work is a review of the present status of the data acquisition and presentation techniques for the SNM method with special emphasis on the solutions adopted at our laboratory.

Scanning nuclear microprobe analysis

A brief introduction to the method will be given and for the description of the complete analytical system the reader is referred to fig. 1.

A beam of charged particles with an energy of a few MeV is produced in a small accelerator, normally an electrostatic generator. The name of the technique implies that only protons are used but alpha particles are often used too, e.g., in RBS or elastic scattering analysis. The beam is allowed to pass through an object collimator with a hole or slit of appropriate size, e.g. tens of micrometres. This object is then demagnified in a lens system, normally a set of magnetic quadrupoles, and the image is formed on the specimen surface. To limit the incoming beam divergence to fit the acceptance of the probe-forming system, a second collimator is placed between the primary collimator and the lens.

In order to be able to image the specimen surface and to reduce beam-induced temperature increase with possible damage to the specimen, a scanning device is introduced in the beam line. The beam is then

KEY WORDS: computer control, data acquisition, elemental mapping, imaging, microanalysis, Particle induced X-ray emission, scanning nuclear microprobe, VMEbus

*Contact for Correspondence:
K.G. Malmqvist, address and phone no. as above.

set to dwell at each pixel for a very short time (ms) and then move to the next. The short time is chosen to avoid reaching thermal equilibrium in the irradiated spot.

A detailed description of the nuclear microprobe technique is beyond the scope of this work, but for those interested a comprehensive textbook on high-energy ion microprobes has recently been published (26). Several reviews on the various applications of the SNM technique have been published in recent years and for details on the use of the method in these fields the reader is referred to them (24,18,4).

Analytical techniques

When ion beams of high energy (>1 MeV/u) are used to irradiate matter several reactions will take place. As a result of Coulomb interaction the ions, similarly to the electrons in an electron probe, will cause excitation and ionization of the atoms which will emit electromagnetic radiation with wavelengths from infra-red to the X-ray region, as well as Auger and secondary electrons. In addition, the ions will be scattered, elastically or inelastically due to interactions with the nuclei, and when certain energy conditions are fulfilled the cross sections for nuclear reactions may be significant. Through a suitable choice of detectors to register the various components of radiation all these interactions may be utilized in the analysis of matter. The following presentation of various radiation components demonstrates the importance of this multiparameter capability and the consequently complex data acquisition systems employed in nuclear microprobe systems.

Photons

The detection of X-rays is one of the most important methods and in the case of MeV ions (PIXE (13)) this has almost entirely been accomplished with energy-dispersive systems. The ionization probability using protons of MeV energy is of the same order as that of electrons of keV energy. However, the low intensity of the continuous background radiation, compared with that encountered with electrons, yields a relative analytical detection limit which is normally more than two orders of magnitude lower than for the electron probe. In micro-analysis, when using proton beams with diameters of a few micrometres or less, it is very important to maximize the solid angle of detection due to the limited beam current available and the resulting low count rate.

The low-energy photons produced during ion bombardment may also be used corresponding to the cathode luminescence technique in electron probes. However, this has, to our knowledge, not yet been employed in the case of particle probes.

Nuclear reactions

In addition to the detection of X-rays, the nuclear reactions which may take place produce gamma rays and charged particles which can be utilized in the characterization of matter. Particle induced gamma-ray emission (PIGE) and nuclear reaction analysis (NRA) are useful techniques (26), in particular for the analysis of light elements. For the heavier nuclei the Coulomb barrier prevents an incoming particle of low energy from interacting with the nucleus and causing nuclear reactions. The probabilities (cross sections) of most nuclear reactions also vary significantly with the velocity of the impinging ion and by varying the primary energy the depth distribution in the specimen of a particular element may be investigated.

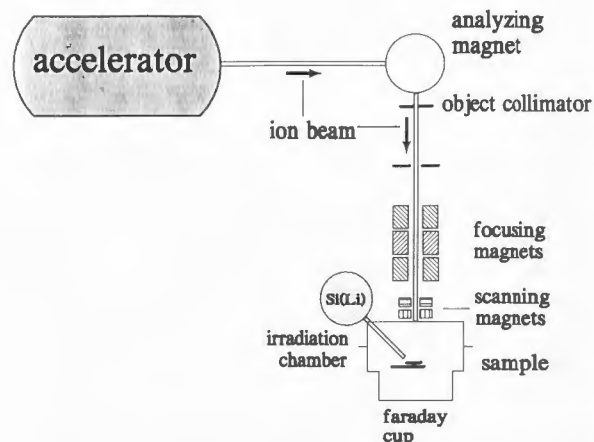

Fig.1. The main components of a system for scanning microprobe analysis. The drawing is not to scale. Si(Li) is the X-ray detector used in microPIXE analysis.

In the detection of gamma rays, solid state detectors, Ge(Li) or HPGe, are normally used. Due to much lower cross sections for nuclear interactions compared with atomic reactions, the demand for high detection efficiency in micro-analysis is even more pronounced than in the case of X-rays. The charged particles emitted are measured with surface barrier detectors which may be placed in forward or backward directions or annular to the beam. For the low-intensity beams used in micro-analysis, arrays of surface barrier detectors may be used to increase the detection efficiency (7).

Scattered ions

The classical analytical method based on scattering mechanisms is the Rutherford Backscattering (RBS) technique (3). The momentum of the scattered ion is dependent on the mass of the scattering nucleus and by determining the momentum, the isotope can be determined. To fulfil the Rutherford conditions heavy ions of relatively low energy (typically alpha particles of 2 MeV) are used in conventional RBS. However, general particle elastic scattering, PESA, which does not necessarily fulfil the Rutherford condition for scattering cross sections, may be used for protons of higher energies. The scattered ions are detected in surface barrier detectors, as discussed above. The lighter elements can be analysed since the adjacent elements can be resolved while the detector is not able to resolve the heavier elements. For the determination of hydrogen, elastic recoil detection is used. Hence, surface barrier detectors are placed in the forward direction to detect the recoiling ions either through the sample or from the surface of the sample which is then tilted by a large angle.

Using a forward detection system at 0° it is also possible to measure the energy loss of the primary ions when passing through thin samples undergoing only small-angle scattering. This method cannot be used for elemental analysis but can be used to measure the thickness of the sample at each pixel and can consequently be used for imaging the sample (Scanning Transmission Ion Microscopy, STIM (20)). This technique is mainly used with heavier ions and only requires a few ions in each pixel since the range and

slowing-down of heavy ions is well defined. This means that only a very low ion current is required for the imaging/sample thickness measurements. Hence ion beams down to a diameter of 0.05 micrometres can be used and the imaging resolution will thereby be significantly enhanced (1). In a special application of the energy loss during transmission, ion-beam-based computer tomography can be used (see below).

Electrons

Secondary electrons may be used for the imaging of the surface of the specimen (15). The lateral resolution is limited by the size of the incoming particle beam which is normally > 1 micrometre. Detection may be carried out using traditional scintillation detectors or channeltron tubes. By changing the acceleration voltage for the electron collection, different electron energies may be selected in order to enhance the secondary electron image contrast.

As in the case of electron probes, Auger electron spectroscopy based on ion beams may possibly be used to investigate the distribution of elements in the very near surface layers. To the author's knowledge this has not yet been done successfully, but an appropriate electron spectrometer system and an ultra-high-vacuum irradiation chamber would be the experimental requirements.

Data acquisition, processing and presentation

There are several ways of designing a data acquisition system for a scanning nuclear microprobe. It is assumed that the analysis is performed with a scanning beam or scanning sample in order to produce two-dimensional distributions of the elements. Fig. 2 shows a schematic arrangement for SNM analysis, together with three different principal approaches to the data acquisition (26). A very simple approach is to record a *single* energy spectrum from, e.g., X-rays or scattered particles, while rastering the specimen region selected. In this case, scanning is only used to prevent high-temperature effects, and the approach will obviously not produce any information on the lateral distribution of the elements detected. To obtain one- or two-dimensional distributions of the elements, the beam scanning can be synchronized with a CRT display (storage oscilloscope) and, using single-channel analysers, pulses representing different energies of the detected radiation can be selected to modulate the intensity of the CRT. In this way line scans or elemental maps of single elements can be produced with various degrees of sophistication. The third and most useful approach is to use a multiparameter data acquisition technique.

The suggested techniques can be varied depending on the available hard- and software and on the demands of the particular application. In the following, the details of data acquisition systems yielding two-dimensional information will be discussed.

Scanning

The scanning procedure is intimately connected to the data acquisition process. The pixel-by-pixel analysis can be carried out in two different ways; moving the beam or moving the sample. The advantage of the second approach is the avoidance of introducing any extra beam aberrations but, on the other hand, the scanning speed is severely limited by the mechanical movement of the sample (2). The scanning frequency of the first approach is only limited by the physical

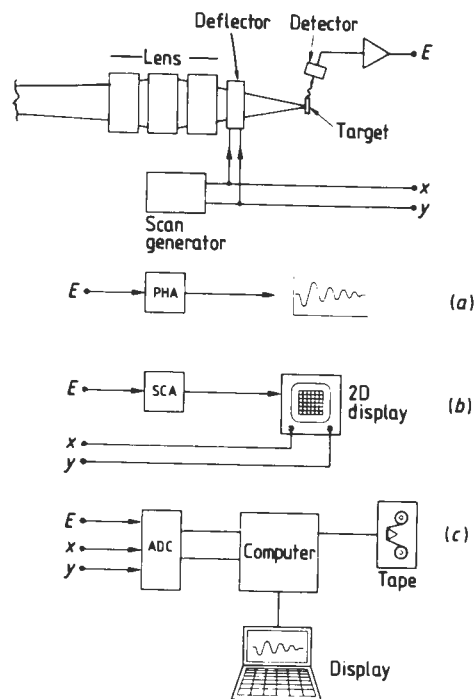

Fig. 2. Data acquisition systems for scanning ion beam micro-analysis (26). The upper diagram indicates the origin of the signals. a) Simple spectrum recording. b) Single-channel mapping. Pulses are selected using single-channel analysers which produce bright points on a two-dimensional storage display, which is scanned synchronously with the ion beam. c) Multiparameter data recording. The recorded single events are stored on tape (list mode).

properties of the scanning device. If electrostatic deflection is used the frequency can be relatively high (100 kHz-1 MHz), while in the case of magnetic deflection the scanning is limited to lower frequencies (1-10 kHz). The basic requirement on the scanning speed is that the beam should *not* reside on one pixel long enough for the area to reach thermal equilibrium, since an increased local temperature will normally elevate the elemental losses due to radiation damage.

When deflection plates are used the limitation is set by the electrostatic field required to produce a suitable scanning amplitude. Using long plates, a low field may be used but then the plates occupy too much space between the lens and the chamber. If short plates and high gradients are used the risk of electric discharge is high. The deflection system must then be placed *before* the focusing system and will consequently cause increased beam aberration when the beam is deflected off the optical axis. However, by proper positioning of the scanning device the aberrations can be minimized by allowing the beam to cross the optical axis in the optical centre of the lens system (8). If magnetic deflection with iron cores is used the magnetic field can be relatively high before saturation is reached, thus allowing post-lens scanning. The scanning frequency will, however, be limited and therefore it is advisable to use ferrite cores instead, allowing a scanning frequency of 10 kHz (25).

The scanning procedure can conveniently be

controlled by the same computer system which controls the data acquisition (17). Other solutions including hardware-controlled scanning systems are much less flexible and do not allow efficient use of the beam time with asymmetric regions of interest on the specimen.

Data collection and storage

Several parameters may be of interest in scanning nuclear microprobe analysis. To make full use of the capabilities of the technique it is essential to collect data in a manner which allows for a two-dimensional presentation of the results. As mentioned above, one very straightforward way of doing this which requires no computer, is to use the signals from the various detectors to modulate the intensity of a storage oscilloscope trace which is synchronized with the beam scanning. The total intensity of the X-rays, an energy window set at an interesting X-ray line or the secondary electron intensity are examples of input parameters which can be used in this simple approach. The results on the CRT screen are only qualitative and are suitable, for example, for orientation on the specimen. This approach is most useful in combination with secondary electrons and fast scanning of the specimen. Due to the limited resolution of the proton beam (>1 micrometre) the image thus obtained is not as useful as the image in a scanning electron microscope, but may still be quite useful for selection of a suitable position to perform quantitative trace element analysis.

A more useful approach is to make use of computer control and to use a scheme similar to that shown in fig. 2c. Each detector has its own analogue-to-digital converter (ADC) which, when triggered by an event, will start processing the pulse and read-out of the position of the beam defined by its x and y coordinates values. The single event represented by these three digital numbers is then stored on disk or on tape for subsequent analysis off-line. This event-by-event storage (list-mode) may be performed at several thousand pulses per second and large amounts of data are collected. Since the data are stored in time sequence the data may also be used to monitor possible sample deterioration which may take place due to radiation damage of the specimen. Furthermore, using powerful off-line computer evaluation, several elemental maps for pre-selected energy windows may be quickly produced. By combining X-ray data with, e.g. scattered particles detected in surface barrier detectors, it is also possible to determine the sample thickness (mg/cm²) in each pixel, e.g., to correct for proton slowing-down or X-ray attenuation, and to calculate the elemental concentrations. To improve the accuracy of these determinations the beam charge in each pixel may also be determined. To get an accurate measure of the charge in each pixel a very sensitive (<10⁻¹³ Coulomb/pulse) current integrator is a prerequisite with beam currents down to 100 pA, which, as a rule of thumb, is regarded as the lowest current useful for quantitative analysis.

With the list-mode approach described above it is possible to obtain information about time-dependent effects (radiation damage) occurring in the specimen. However, in large-scale investigations with many samples or when many pixels are analysed in each sample, it is difficult to process such a large amount of data. In addition, the data storage will require magnetic tapes since a large disk, e.g. 0.5 GB, will be full within hours of analysis.

It is advantageous to find ways of reducing the amount of data on-line during the course of data

acquisition. One common technique is to acquire one spectrum per pixel and store them. Data reduction can also be achieved by partial sacrifice of the time information and by pre-sorting the events in blocks according to energy and storing these blocks in consecutive rows. Another approach would be to select all the interesting parameters at the start of the experiment and calculate quantitative elemental maps on-line which are then stored instead of the raw data. One group using these techniques is the SNM group in Oxford, UK, which after entering more intensive analytical work (essentially 8 h a day of irradiation time) has changed from event-by-event storage of raw data to direct evaluation giving elemental maps followed by spot analysis of selected regions (11). This results in a tremendous reduction in the amount of data and the need for off-line evaluation is completely removed. However, at the data acquisition rate suggested above, detecting, e.g., X-rays, scattered protons, emitted particles and measuring accumulated charge and electronic dead-time, which should all be used in the calculation of the quantitative results, it is necessary to have on-line access to a powerful computer system, preferably including a vector processor unit and a graphic work station for fast update of the on-line elemental maps.

A combination of list mode with perhaps partial data reduction and on-line presentation of *qualitative* results in the form of, for example, elemental maps, would probably be a suitable compromise which would be useful for large-scale investigations using the scanning nuclear microprobe. An example of such a system will be described in detail later.

Processing of raw data - quantification

The parameters obtained during SNM analysis are dependent on the detectors employed. The evaluation of the results can vary from crude qualitative results giving sufficient information in a particular application, to highly accurate quantitative data which may be required in other studies.

In the scanning analysis mode which can produce laterally resolved information, there are, due to poor pulse statistics, significant limitations to the detection limits attainable. If a large scan of, e.g. 128x128 pixels is performed it is only possible to determine the distribution of major or minor elements, as the number of detected events does not allow for the determination of trace elements in each pixel. To perform genuine trace element determination, which is the strong feature of microPIXE analysis, it is necessary to pool several pixels together, to analyse a very small two-dimensional area containing a few pixels or to scan one-dimensionally (line scans), thereby limiting the number of pixels significantly.

When performing a traditional PIXE or RBS analysis each individual spectrum obtained is evaluated using various computer codes (26,5). This can similarly be done in the case of SNM analysis for the major and minor elements but with restrictions on the number of spectra feasible to process. In the example above, the total number of pixels from one analysis is 16,384 prohibiting the use of traditional techniques. If individual spectra from smaller area scans, e.g., 64x64 pixels, obtained from event-by-event data are to be evaluated off-line the time required to process a spectrum should still be a few seconds or less, including sorting and evaluation. In PIXE spectra the limited number of counts in the continuous background makes it difficult to determine the background level

accurately and effects from peak tailing due to the detector may interfere. By determining the tails in detail (14) and using physical models for the calculation of the secondary electron Bremsstrahlung continuum based on knowledge of the matrix composition (19) it may be possible to decrease the time required by existing X-ray peak stripping codes significantly. Peak stripping is only part of the quantification procedure and the X-ray dead-time, the specimen thickness (obtained from RBS spectra) and the accumulated beam charge all have to be determined and included for accurate results.

Presentation of results

When using the various methods of determining two-dimensional elemental distributions it is essential to find suitable ways of presenting the results in an easily understandable manner. The results are often used and interpreted by scientists in other fields who are not experts on the analytical methods. Image processing is growing rapidly and is being applied in many fields of science. The methods developed for image-enhancing should preferably also be applied in the evaluation and presentation of SNM results.

A very straightforward method of displaying SNM results, quantitatively or qualitatively, is to show the two-dimensional distribution of an element, for example, as a grey-coded elemental map (see fig. 3). The elemental concentration or the X-ray intensity is displayed as a varying monochrome intensity or density of dots. The capacity of the human eye to see small changes in this kind of display is quite good. A more sophisticated method is to use a colour-coded map. Several colours can then be used to increase the image contrast according to concentration, and to highlight particularly interesting features. However, such an approach requires a careful selection of colours which is easily interpreted as varying concentrations. With grey- or colour-coded images various methods of image processing, for example, smoothing (21) may also be used to facilitate interpretation. Another way of expressing varying concentrations is to use contour or isometric plots. In fig. 4 an example of contour plots of elemental distributions within a single cell is shown (16).

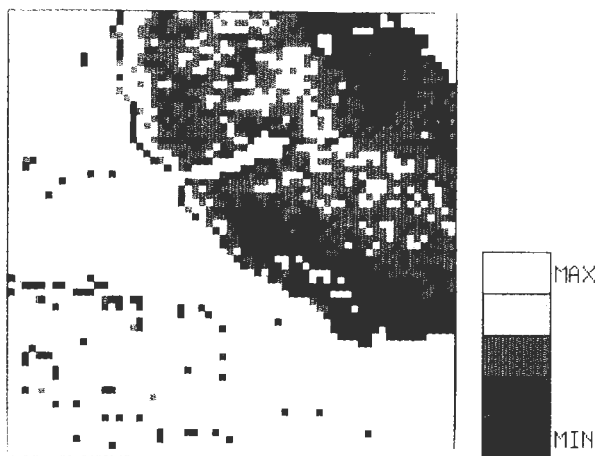

Fig. 3. A grey-coded elemental map of potassium distribution in a thin section of human skin. The scan size is 64x64 pixels with a beam size (= pixel size) of 20x20 μm^2 (2 nA, 2.5 MeV protons).

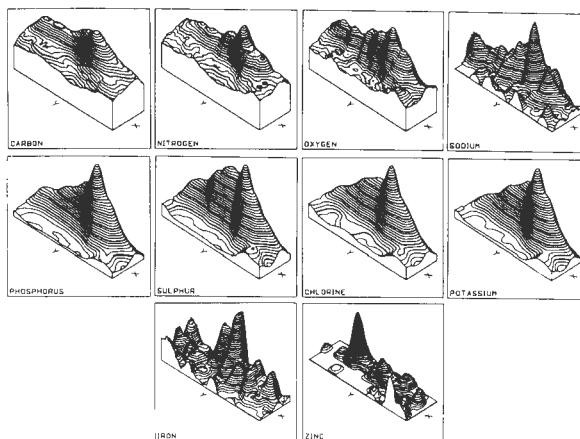

Fig. 4. Three-dimensional contour map of fibroblast cell. Elements up to Na were obtained by RBS. Phosphorus and above were obtained with PIXE. Scan size is 24x144 μm^2 and the resolution is 3 μm with 3 MeV protons (16).

The Lund scanning nuclear microprobe data acquisition system

As an example of a comprehensive system for data acquisition, the complete system of the Lund scanning nuclear microprobe for scanning control, data acquisition, data storage, quantification and data presentation will be described in some detail.

Our department uses a Nuclear Data ND9900 computer based on a $\mu\text{Vax-II}$ computer as a multichannel analyser. This is used as a host computer to a secondary computer system which manages the data acquisition and beam control. Using this method, the secondary computer system can be dedicated to the time-consuming work of data acquisition and beam scanning while leaving the $\mu\text{Vax-II}$ free for running on-line data evaluation programs, e.g., elemental mapping.

The secondary computer is a VMEbus system. The concept of the VMEbus is very flexible and is ideal for data acquisition and control systems easily allowing tailor-made functions to be incorporated for a specific type of analysis. Since the VMEbus is a 32-bit data and 32-bit address bus, it has very fast access to an almost unlimited address space. It is a multiprocessor system, and several manufacturers today offer processor modules based on fast 32-bit microprocessors and VMEbus modules with all kinds of control and in- and output functions. In addition, the VMEbus has become an industrial standard and is hence well documented and tested as well as advantageously priced. This bus system is also attracting increasing interest in experimental physics in general (23) and has also been adopted in other nuclear microprobe systems (11).

This system forms a powerful means for control and data acquisition. It is used with a large disk storage (0.5 GB), magnetic tapes and terminals and plotters for colour display. A software system has been developed to facilitate flexible user control of the data acquisition and beam scanning during the analysis.

The scanning is performed with a ferrite-cored magnetic system *after* the focusing lenses, and has been described in detail previously (25). The scanning is controlled by a digital-to-analogue converter (DAC)

which controls the power supply for the magnetic coils. Any preselected scanning pattern can be used and changed during the analysis. The computer allows the beam to dwell for milliseconds on each pixel and then moves to the next in a regular or an irregular pattern. The present system allows post-lens scanning of an area of approximately $2 \times 2 \text{ mm}^2$ with a minimum dwell time of 0.1 ms. The movement from one pixel to the next can be selected based on the live dwell time, the accumulated charge, a number of events or any other suitable parameter. In our system a combination of data processing on- and off-line is used. The details of the computer systems used are given below.

The VMEbus system

A block diagram of the computer system is shown in fig. 5. The VME system consists of a total of ten modules: two processor modules, a DMA link to the $\mu\text{Vax-II}$, a 2 MB RAM memory module, a graphic display controller and five in- and out-modules for data acquisition, beam scanning and control. The first processor module, a Motorola MVME133, is the VMEbus controller. It is a 12.5 MHz processor with a floating-point co-processor and 1 MB on-board RAM memory. The second processor module, a Motorola MVME105, is used for control of the in- and out-modules.

The DMA link module links the VME system to the $\mu\text{Vax-II}$ host computer via a 16-bit parallel interface. Data transfer rates of up to 0.5 Mb per second can be achieved which is sufficient for most requirements. Data can be transferred in either direction and initiated by either computer interrupting the other. The parallel ports connect four ND (Nuclear Data) ADCs to the system. The ND handshaking sequence is controlled by an adapter module, connected between the ADCs and the VMEbus acquisition modules. Of course, an ADC module connected directly to the VMEbus would be much faster and more convenient, but no such suitable commercial modules have been found.

The scaler module is a four-channel counter module, one channel for each ADC. The unit is implemented for collecting pulses from a current digitizer for beam charge monitoring of the Faraday cup. The current digitizer signal is split into four identical signals, one for each ADC. Each signal is gated by the slowest device in the corresponding pulse-forming link between the detector and the VMEbus acquisition modules. Using this method, beam charge accumulation is avoided when a pulse is being processed in the front-end electronics.

The list-mode protocol used is of a non-uniform type. The sequence of energy events is terminated when a new pixel is to be irradiated. The energy events acquired are followed by the new pair of co-ordinates and data from the old pixel: the (gated) beam charge of each detector, the irradiation time of the pixel and, finally, the device that triggered the beam to move to the next pixel. This gives a maximum of eight parameters in addition to the number of energy events recorded.

The DAC module controls the scanning of the beam. New beam co-ordinates are loaded by the second processor into an x and y register in the module. The corresponding parallel word is converted and fed to a voltage-to-current amplifier which controls the scanning magnets. Additionally, a graphic display controller is implemented for the display of statistics and information about the current analysis. A digital input and output module controls the target chamber

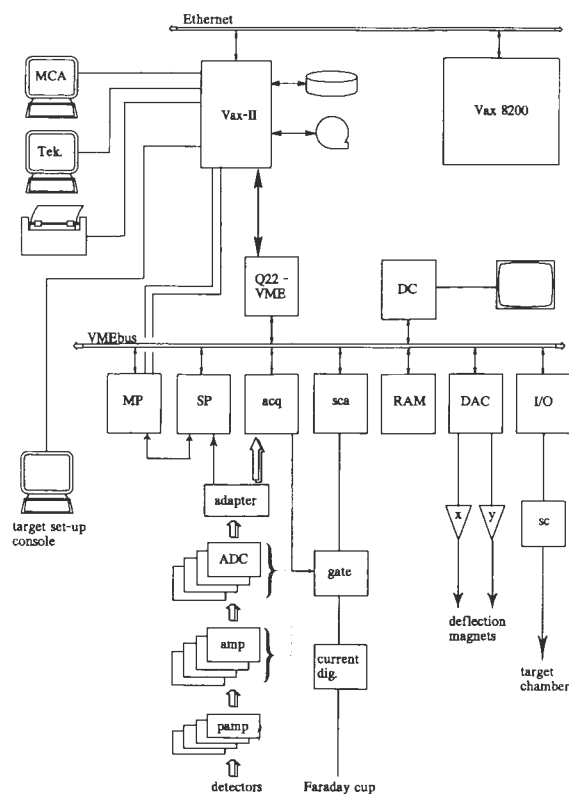

Fig.5. Schematic diagram of the data acquisition and beam scanning system at our department. The notations are as follows: acq - acquisition modules, ADC - analogue to digital converter, amp - amplifier, DAC - digital to analogue converter, DC - display controller, I/O - digital input/output module, MCA - multi-channel analyzer, MP - master processor, pamp - preamplifier, RAM - memory board, sc - stepping motor controller, sca - scaler board and SP - slave processor.

mechanisms, such as the stepping motors for sample positioning.

The host computer

To facilitate fast on-line data evaluation, the capacity of the ND9900 has been increased considerably compared with the basic version. A new Winchester disk system has been installed which gives a total disk storage of more than 0.5 GB. The RAM memory has been increased to 7 MB and an Ethernet™ controller has been installed for communication with a Vax 8200 computer located at the Institute. Thus, off-line evaluation of SNM data can also be accomplished on the Vax 8200.

Elemental maps (see data presentation below) are constructed on a Tektronix 4109 graphic display terminal connected to the $\mu\text{Vax-II}$ via a serial link with a data rate of 19200 baud. The 19" screen has a resolution of 640 by 480 pixels. Colours can be chosen from a palette of 4096 distinct colour mixtures, and 16 of them can be shown simultaneously. A drawback with this system is the low speed of serial data transfer, i.e. the user has to spend some time waiting while a map is drawn. A planned graphic controller coupled directly to the $\mu\text{Vax-II}$ Q22-bus and a graphic monitor,

will reduce the waiting times.

Acquisition concept

The acquisition model employed by us is based on an infinite loop. The processor runs in a loop and tests the READY flag of the ADCs and takes the proper action in accordance with the ADC status. Up to 10,000 pulses per second in each detector can be processed with our system. As the different ADCs compete with each other, a count rate of 40,000 cps can be handled if only one detector is activated. Again, the maximum acquisition frequency is set by the clock frequency of the microprocessor. With the fast processors available today, the maximum count rates mentioned above could be at least doubled. This model for data acquisition also facilitates easy upgrading of the system since more detectors, such as a Si(Li) detector array, can be added to the system without restraining the maximum count rate per detector. This is done simply by adding new processor modules and doing some minor re-programming.

User environment

A comprehensive software package has been developed to facilitate flexible and "easy to perform" analyses. Two programs are executed simultaneously in the VMEbus system, one for each processor module. The part of the program package which communicates with the user is completely executed in the first processor module, as mentioned above. This program facilitates operator control of an analysis and provides information to the user. Before sample analysis, the user sets up various system parameters using a "command style" input language. These parameters may be set up in any order and some of them can be changed during the sample analysis. The first parameter set defines the scanning frame. One of two modes of scanning can be chosen by the user, irregular or rectangular. If a rectangular frame is selected, the number of x and y pixels, as well as the number of steps between them, has to be chosen between 1 and 4096. When an irregular scanning frame is selected, the x and y co-ordinates for all pixels to be irradiated must be chosen individually.

The second parameter set defines the input of the beam trigger, i.e., the trigger for moving the beam to the next x and y co-ordinates. When the dwell-time trigger is selected, the beam will move to the next pixel after a preset time, between 0.1 msec and virtually infinity, has elapsed. In a similar way, the charge trigger will trigger the beam scanning whenever a preset charge has been accumulated by a selected scaler and the pulse counter trigger will trigger the beam scanning after a preset number of events have been acquired by a selected ADC.

As mentioned above, some of the parameters can be altered during the course of the analysis. The scanning frame, for example, can easily be redefined by using command inputs or the arrow keys on the terminal keyboard. Hence, it is possible to perform for example a real-time zooming of the scanning frame on the sample.

Data sorting and presentation

Three codes are used in parallel on the μ Vax-II computer. The first stores data on a disk at the highest rate possible. The primary data are received as large blocks and are stored directly in the same form. The second code, SORT, reads primary data from the disk, sorting it into elemental maps and spectra. The third

code, MIKRO, is the graphic display code (see below).

Sorting

Primary data are sorted by applying spectral energy windows and similar techniques. The sorting produces elemental maps of the sample, i.e., two-dimensional maps representing the distribution of X-ray pulses or pulses from scattered particles in selected energy intervals, as well as energy spectra from regions of interest chosen in the analysed area. Further, the code normalizes the elemental maps with the accumulated charge per pixel, and corrects for variations in sample thickness, as measured by some suitable method, e.g., PESA. It also records elemental losses due to beam damage, and by combining X-ray energy windows with suitable information on, for example, X-ray absorption, particle stopping power and cross-section variation, makes semi-quantitative results possible.

The sorting code SORT can work in three different on-line modes:

i) direct sorting during analysis followed by storing of the final elemental maps on disk, primary data is lost, ii) storing of primary data on disk, iii) sorting of data previously stored on disk. This mode is normally used during analysis providing online sorting.

Elemental maps are constructed and stored in the form of twenty 64x64 pixel matrices. In the default disposition there are eight maps available for X-rays, three for RBS data, one for energy loss data, two maps for an extra detector, and six for scaler data, but other configurations are possible. Background subtraction using a simple model can be performed. Regularly, during the sorting procedure and at the end, the peak background, defined as the mean value of the two limiting channels, is subtracted from each energy window, thus facilitating the production of elemental maps with live background correction. Energy spectra can be produced from any pixel or pixel combination, i.e., region of interest. After sorting, elemental maps and spectra are stored on disk. Normally during analysis, two images of SORT are active, the first receives and stores data while the second image sorts the data.

Quantification

Before displaying the results from the PIXE analysis it is useful to be able to calculate actual quantitative values of elemental concentrations. As has been briefly mentioned above, this is traditionally performed on an X-ray spectrum by a spectrum-fitting computer code which produces the X-ray line intensities and, with a suitable data-base, calculates the corresponding masses of the elements. For non-thin specimens corrections are performed using sample thickness and composition from, for example, RBS data, to calculate X-ray attenuation and particle slowing-down. Finally, the values are normalized to concentrations. Such procedures can be used for added spectra from a two-dimensional SNM scan or for each pixel in scans of very few pixels. However, as has been discussed above this is not feasible for each individual spectrum in a large scan. For presentation of data from such analyses the two-dimensional maps are normally only semi-quantitative, i.e., a simple X-ray window technique normalized for sample thickness. Instead, especially interesting features are added together as a number of pixels and the summed PIXE spectrum used for quantification.

In some cases, for example, in biological samples,

it is important to actually calculate fully quantitative results for a rather large number of spectra and then the traditional codes used for evaluating PIXE spectra are far too time-consuming, even when using the most powerful means of data processing, e.g. vector processors. A different approach then has to be used when determining the line intensities. In a project to investigate the effects of radiation-induced damage in organic matrices a systematic investigation has been made of the production of continuum radiation in the spectra. The effects of varying composition on the Bremsstrahlung production have been investigated systematically (19). From knowledge of the main composition, for example, from PESA data, it is possible to accurately calculate the background radiation intensity. Furthermore, determination of the low-energy peak tailing for the individual X-ray detector enables us to subtract this effect together with any possible pile-up and escape peaks. The development of a computer code for organic matrices using this approach is in progress at our department.

The computer program starts with the sorted spectra from each pixel and one spectrum obtained by adding all the individual spectra together. A preprocessing of this summed spectrum is performed using the code HEX (12) thus obtaining an energy calibration and due to the good pulse statistics in the summed spectrum, accurate total amounts of many elements within the scanning frame. The PESA spectra are evaluated using a newly developed, dedicated computer programme (9) in order to determine a preliminary sample composition and sample thickness in each pixel. This elemental composition of the matrix is used to determine the approximate background level for each X-ray spectrum and to strip the peaks using a simple technique. Corrections for X-ray attenuation and particle slowing-down and normalization are also made using the preliminary thickness.

Once an accurate composition is known the accurate background levels can be calculated and after subtraction of peak tailing and any pile-up and escape peaks the final X-ray line intensities can be determined. After calculation of the concentrations in each pixel the summed elemental amounts from all pixels can be compared with the results from the HEX evaluation of the summed spectrum.

Since the very time-consuming spectrum-fitting is avoided in this simplified spectrum evaluation technique a typical biomedical sectioned sample can be evaluated with a very short computer time per pixel (a few seconds using a μ Vax-II is expected in the final version). In the off-line computation, for the subsequent presentation of the results, these quantitative results are then used instead of the qualitative results.

Presentation

Finally, the sorted data may be presented in a user-friendly way, allowing the user to carefully inspect and control the acquisition and sorting process during analysis. The presentation is performed by the code MIKRO which displays the elemental maps in suitable forms and combinations. One, two or eight colour-coded elemental maps can be shown simultaneously together with the corresponding colour scale (or grey scale, if preferred). From the set of sorted elemental maps or from the fully quantified maps, two pictures, each composed of one or more maps, can be chosen to be shown on the screen. These combinations are ordered from MIKRO. In order to increase the visibility of a map, a function for smoothing the picture can be

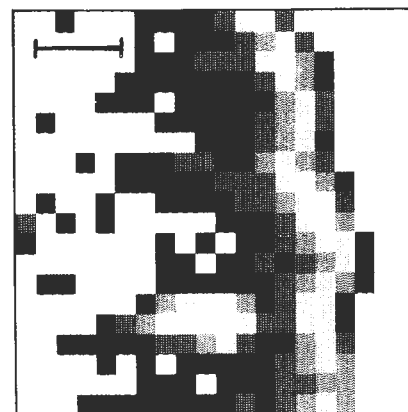

a)

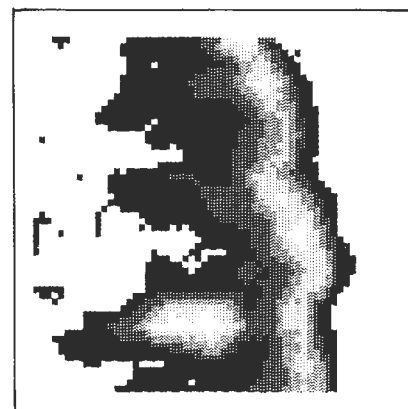

b)

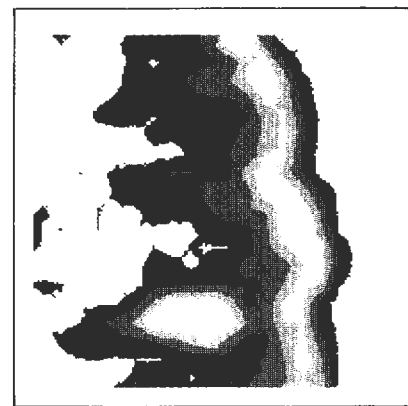

c)

Fig. 6. Grey-coded elemental maps (phosphorus) demonstrating the effects of smoothing the original data. The smoothing is performed linearly in two steps from a) to c). The bar is 100 μ m.

implemented. In fig. 6 an example of the smoothing effect is shown.

The SORT and MIKRO codes work with relatively small elemental map sizes. The limitation to 64x64 pixels is mainly due to the balance of pulse statistics versus quantification in PIXE analysis. At an X-ray count-rate of 1000 counts/sec ofs, one hour of irradiation of a 64x64 pixel matrix will give less than

1000 pulses per pixel. Of those, in organic matrices normally 90% will be found in the lighter elements and the background, leaving only less than 100 pulses for heavier elements, which is the minimum for quantification. Increasing the map-size to 256x256 pixels will reduce the amount of data in each pixel by a factor of 16, removing the solid base of quantification. If, on the other hand, the main emphasis is on elemental imaging of the main constituents, a larger map-size will not impose the same limitation.

Colour scale and data normalisation

When comparing several elemental maps in order to find similarities or dissimilarities, by looking at colour coded information, problems often arise. The colours used are associated with a temperature scale; the colour white representing the highest values, decreasing through yellow, orange and red. The lowest values are represented by blue and dark blue colours. In order to visualise different elemental maps in similar ways, a normalization procedure is available. For each element, it subtracts the mean value of all data in a map, and divides by the standard deviation. The distribution of the displayed values will then be standardised, and the same colour scale will approximately hold for all elements.

A more accurate way of finding similarities is to adopt statistical methods capable of handling multivariate data. Several methods working in the multidimensional space spanned by the different elements exist. To make use of such computer codes, it is necessary to convert the files of the stored elemental maps into files with a special format.

Smoothing

In the elemental maps, each pixel corresponds to an irradiation point on the sample. The pixels are represented by closely arranged squares. For increased visibility, a smoothing function has been implemented. Starting with the original 64x64 pixel picture, a new matrix is formed by first enlarging the old picture three times while keeping the pixel size constant. The empty positions surrounding these original pixels, are then given interpolated values. This procedure, which does not alter the original data, will give a picture with smoother borderlines but, a false impression of increased spatial resolution. It is meant to be an aid when investigating the data, and it is necessary that the smoothed picture is used together with the original one in order not to draw erroneous conclusions during the interpretation (21).

Special SNM analysis

In a special form of STIM, computer-aided tomography (CAT) based on ion micro-beams may be used to investigate the three-dimensional shape of small objects (22). The sample under investigation is rotated and translated in the ion beam and the transmitted beam is energy analysed with a surface barrier detector. Computer codes based on those used for traditional X-ray CAT scanning are used for the reconstruction. In fig. 7 an example of the experimental arrangement for such an analysis is shown (10).

Another approach to three-dimensional analysis using the SNM is to use RBS or resonant nuclear reactions to vary the analysing depth during the scanning and after sophisticated processing produce three-dimensional distributions (6). Using the new powerful graphic work stations and three-dimensional software this could be even further developed (BL

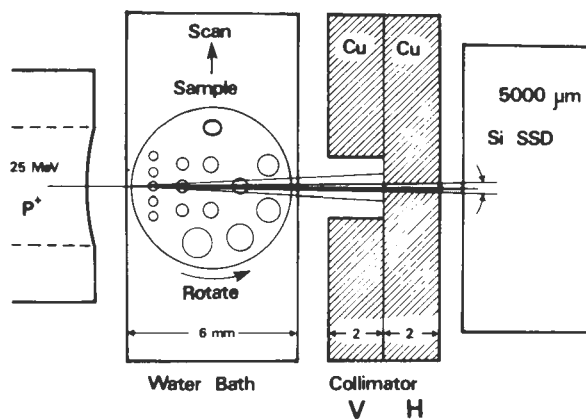

Fig.7. An experimental arrangement for a proton tomographic measurement (10).

(Doyle, private communication).

Conclusions

From the discussion above concerning various aspects of data acquisition, storage, processing and presentation it is evident that computer hardware as well as software is very important for the effective use of scanning nuclear microprobe techniques. Due to the high complexity of the nuclear microprobe which, in addition to traditional imaging by secondary electrons, uses several detector systems, many parameters have to be acquired and subsequently evaluated to yield as much information as possible about the specimen. The best technique for doing this is to acquire the data in list mode for off-line evaluation. As in the case of the electron probe the beam-induced effects in the sample may be substantial and the list mode acquisition can then also be used to monitor and correct for any such effects.

A system based on a combination of VMEbus and μ Vax-II computers has been shown to be an effective means of control and data acquisition in a scanning nuclear microprobe system.

The limitation in using the list-mode protocol is mainly the vast amounts of data collected. As has been discussed above, the computer power available, on- as well as off-line, will set the limit on how fast the acquired data can be evaluated. The increased use of graphic work stations based on the RISC technique and vector processors will allow much more rapid evaluation of nuclear microprobe data.

Acknowledgements

The work discussed here, originating from the laboratory of the authors, is in part supported by grants from Swedish Natural Sciences and Medical Research Councils (NFR, MFR, FRN).

References

1. Bench G, Legge GJF (1989). High Resolution STIM, Nucl. Instr. Meth. B40/41: 655-658.
2. Bos AJJ, van der Stap CCAH, den Ouden JC, Vis RD, Verheul H (1986). Description and Performance of the Amsterdam Nuclear Microprobe, J. Trace Microprobe Tech. 4: 57-91.
3. Chu W-K, Mayer JW, Nicolet M-A (1978). Backscattering Spectrometry, Academic Press, New York, 384 pp.
4. Demortier G, (1988). Application of Nuclear Microprobes to Material of Archaeological Interest, Nucl. Instr. Meth. B30: 434-443.
5. Doolittle L (1986). A Semiautomatic algorithm for Rutherford Backscattering Analysis, Nucl. Instr. Meth. B15: 227-231.
6. Doyle BL, McGrath RT, Pontau AE (1987). External PIXE Analysis of the ALT-I Pump Limiter, Nucl. Instr. Meth. B22: 34-39.
7. Günzler R, Schüle V, Seeliger G, Weiser M, Böhringer K, Kalbitzer S, Kemmer J (1988). A Multisegment Annular Si-detector System for RBS Analysis. Nucl. Instr. Meth. B35: 522-529.
8. Heck D (1978). A Proton Microbeam Deflection System to Scan Target Surfaces. Kernforschungszentrum Karlsruhe Internal Report KfK 2734, 12pp.
9. Hult M, Themner K (1989). A Fast and Robust Algorithm for Quantitative Analysis of H, C, N and O in Biological Samples, in: Quantitative Microanalysis with a Nuclear Microprobe, Thesis, LUTFD2/(TFKF-1014)/1-99/1989.
10. Ito A, Koyama-Ito H (1984). Possible Use of Proton CT as a Means of Density Normalization in the PIXE Semi-Microprobe Analysis. Nucl. Instr. Meth. B3: 584-588.
11. Jamieson DN, Grime GW, Watt F (1989). The new Oxford Scanning Microprobe Facility, Nucl. Instr. Meth. B40/41:669-674.
12. Johansson GI (1982). Modification of the HEX Program for Fast Automatic Resolution of PIXE Spectra, X-Ray Spectrometry 11: 194-200.
13. Johansson SAE, Campbell JL (1988). PIXE - A Novel Technique for Elemental Analysis, J. Wiley & Sons, Chichester UK, 347 pp.
14. Larsson P, Tapper UAS, Martinsson BG (1989). Characterization of the Response Function of a Si(Li)-detector using an Absorber Technique, Nucl. Instr. Meth. in press.
15. Legge GJF, McKenzie CD, Mazzolini AP, Sealock RM, Jamieson DN, O'Brien PM, McCallum JC, Allan GL, Brown RA, Colman RA, Kirby BJ, Lucas MA, Zhu J, Cerini J (1986). Microbeam Imaging at Micron and Submicron Resolution, Nucl. Instr. Meth., B15: 669-674.
16. Legge GJF, O'Brien PM, Sealock RM, Allan GL, Bench G, Moloney G, Jamieson DN, Mazzolini AP (1988). Design of a versatile, high resolution, high efficiency probe, Nucl. Instr. Meth., B30: 252-259.
17. Lövestam NEG (1989). Development of the Lund Proton Microprobe Scanning and Data Acquisition System, Nucl. Instr. Meth., Nucl. Instr. Meth. B36: 455-470.
18. Malmqvist KG (1986). Proton Microprobe Analysis in Biology, Scanning Electron Microsc. 1986; III: 821-845.
19. Martinsson BG, Themner K (1989). Experimental Cross-sections for Bremsstrahlung Production by the Impact of MeV Protons on Low-Z Targets. Nucl. Instr. Meth. in press.
20. Overlay JC, Schofield RMS, MacDonald JD, Lefevre HW (1988). Energy-Loss Image Formation in Scanning Transmission Ion Microscopy, Nucl. Instr. Meth. B30: 337-341.
21. Pallon J (1989). The Lund Scanning Proton Microprobe Data Sorting and Displaying System. Nucl. Instr. Meth. in press.
22. Pontau AE, Antolak AJ, Morse DH, Ver Berkmoes AA, Brase JM, Heikkinen DW, Martz HE, Proctor ID (1989). Ion Microbeam Tomography, Nucl. Instr. Meth. B40/41: 646-650.
23. Proceedings from conference: VMEbus in Research, October 11-13, 1988, ETH, Zurich, Switzerland.
24. Sie SH, Ryan CG, Cousens DR, Griffin WL (1989). Application of the Proton Microprobe in Mineral Exploration and Processing, Nucl. Instr. Meth. B40/B41: 690-697.
25. Tapper UAS, Lövestam NEG, Karlsson E, Malmqvist KG (1987). A Computer-controlled Magnetic Post-Lens Scanning System for the Lund Proton Microprobe, Nucl. Instr. Meth. B28: 317-324.
26. Watt F, Grime GW (eds)(1987), Principles and Applications of High-Energy Ion Microbeams, Adam Hilger, Bristol UK, 399 pp.
27. Wätjen U (1988). Currently Used Computer Programmes for PIXE Analysis, Nucl. Instr. Meth. B22: 29-33.

Discussion with reviewers

U. Wätjen: In the description of the LUND SPM you mention that you cannot use commercial VMEbus ADCs. What are the essential criteria prohibiting their use?

Authors: The primary reason is that the ADCs, commercially available and based on the VMEbus, sample at time intervals set by an internal clock pulse and not by pulse triggering. This means that a separate triggering system would have to be developed in order to use these units for pulse processing. In addition, the voltage stability of the VMEbus would probably not have been sufficient for this type of measurement.

U. Wätjen: Concerning multivariate data analysis: What do you mean by stating that it is necessary to convert the files of the stored elemental maps into files of a special format? Do you transfer the files to other computing platforms for this sort of data analysis?

Authors: Yes, the multivariate computer code used in processing these data requires another input format for data than that produced during nuclear microprobe analysis.

U. Wätjen: Considering a scanned area of 64x64 pixels, what are the necessary irradiation times for the analysis of respectively 100 and 10 ppm Fe, Cu or Zn on one hand and K or Ca on the other hand in tissue sections?

Authors: This is a pertinent question. Assuming a beam current of 1 nA and tissue sections of approx. 1 mg/cm² the total scanning time required to reach a lower limit of detection for Fe, Cu and Zn of 10 ppm and 100 ppm in each pixel would be approximately 100 h and 10 h, respectively (in this region the detection limit is defined as 10 pulses in the peak). To reach 100 ppm

for K and Ca would take about 50 h. For very special samples, total irradiation times of 10-20 h could sometimes be justified. These examples illustrate the difficulties encountered in reaching true trace element determination in the scanning mode, at least when many pixels are included. Few-pixel or line scan approaches are necessary, when detection limits in the few-ppm region are to be obtained.

U. Wätjen: In Lund you have quite a lot of experience with PIXE analysis (conventional broad beam) for third parties. Would you comment on the feasibility of performing microPIXE analysis for third parties? What would be the approximate costs of a semi-quantitative analysis (elemental maps based on 64x64 pixels) of e.g. tissue sections?

Authors: Obviously the normally used price-per-sample approach would not work for such samples. However, for the analysis of samples using microPIXE, the whole microprobe facility could be rented on an hourly basis. Referring to the answer to the preceding question and assuming a price of 300 USD/h, the estimated cost would be between 500 USD and 1500 USD for a *semiquantitative* analysis.

G.W. Grime: Restricting the reconstructed maps to 64x64 pixels reduces the effective resolution of the microbeam image. Would the use of higher resolution map arrays allow additional visual information to be extracted from the data, even though they are not necessarily true concentration maps?

G.J.F. Legge: In an organic matrix, one is often seeking to map trace elements concentrated in small areas or in areas with sharp boundaries. The trace element yield in the area of interest may be well above average. It will not be great enough to define sharp boundaries, but these can be defined by maps of the major or minor elements or by STIM maps. It is true that accurate quantification of trace elements requires the combination of data from several pixels; but this happens automatically in the extraction of spectra from regions of interest (without the need to loose definition of what may be highly significant boundaries). It does not require the retention of high resolution in the data. Perhaps there is confusion between resolution apparent in the maps and resolution inherent in the data or between uncertainty in yield and uncertainty in position - they are not equivalent.

Authors: We fully agree that the use of a high-resolution scan including many pixels would indeed facilitate various modes of imaging of the sample. This could be obtained by STIM, secondary electrons or by major element maps and could be useful in identifying structures to apply, for example, a consecutive "zoomed" analysis. As can be seen in the answer to the third question above, the analysis times required to reach detection limits for trace elements are very long. When mapping these elements *on-line*, which we regard as being very important, larger pixels are required to see possible structures. Ideally, a high-resolution beam should be used with many pixels to achieve optimal imaging and then for on-line monitoring, software-assisted adding of neighbouring pixels could be used to obtain adequate pulse statistics for trace elements. Both, high and low-resolution maps could then be displayed. However, this requires a great deal of computer power and our present μ Vax-II system is not sufficient.

G.J.F. Legge: In selecting "all the interesting parameters" at the start of the experiment, one would be losing a major strength of the event-by-event mode - that of total information retrieval - and also making assumptions (often unjustified) about the data to be thrown away. In not recording complete spectral information, one also loses the ability to subtract background accurately when needed. Since these were two major considerations in the introduction of event-by-event recording of scanning data in the first place, one should be very wary of such steps, notwithstanding the associated reductions in data to be stored.

Authors: Our data acquisition system normally stores event-by-event. The only information lost in the time sequence of events is within one single irradiation which does not exceed 10 ms due to the high scanning frequency. In the on-line displays, on the other hand, one has to decide which elements one would like to monitor during analysis. If necessary, the elements selected for on-line mapping may be exchanged at any time during sorting. The sorting for elemental mapping during acquisition then has to be terminated and restarted but the acquisition and storing of data may continue unaffected. Only when scanning parameters are changed does the data acquisition have to be restarted.

G.J.F. Legge: Since the measurement of specimen thickness involves the same charge per pixel as the X-ray yield measurement (if performed simultaneously), why do you need the charge per pixel? Is it for different dead-time corrections?

Authors: Yes, to compensate varying dead times in the different detection systems the charge per pixel is required. The dead-time correction in the X-ray spectrometer may be tens of percent, while in the case of particle detector systems it is normally only a few percent.

G.J.F. Legge: Is your beam resolution normally equivalent to the pixel dimensions, or is the beam just sampling the centre of each pixel? This is significant in the consideration of beam damage minimisation and in the interpretation of your maps.

Authors: The beam size is normally equivalent to the pixel size. However, we have recently been investigating the effects of using an overlapping beam while scanning (28). Deconvolution of such primary data reveals more detail than would correspond to the physical beam resolution.

Additional reference

28. Lövestam NEG, Malmqvist KG (1989). Aspects of Elemental Mapping by Means of Scanning μ PIXE Analysis, in Development of a Scanning Nuclear microprobe - Computer-control, Elemental Mapping and Applications, Thesis, LUTFD2/(TFKF-1013)/1-112/(1989), available from our department (see address in front).

1. The first part of the document discusses the importance of maintaining accurate records of all transactions and activities. It emphasizes the need for transparency and accountability in financial reporting.

2. The second part of the document outlines the various methods and techniques used to collect and analyze data. It includes a detailed description of the experimental procedures and the statistical tools employed.

3. The third part of the document presents the results of the study, showing the trends and patterns observed in the data. It includes several tables and graphs to illustrate the findings.

4. The fourth part of the document discusses the implications of the results and provides recommendations for future research. It highlights the areas where further investigation is needed to improve the understanding of the subject matter.

5. The fifth part of the document concludes the study, summarizing the key findings and the overall contribution of the research. It expresses the hope that the results will be useful to other researchers and practitioners in the field.